

peso-weight: 10 kg

1

**FILTRO IN ASPIRAZIONE  
INLET FILTER**  
tipo-type: F14NG

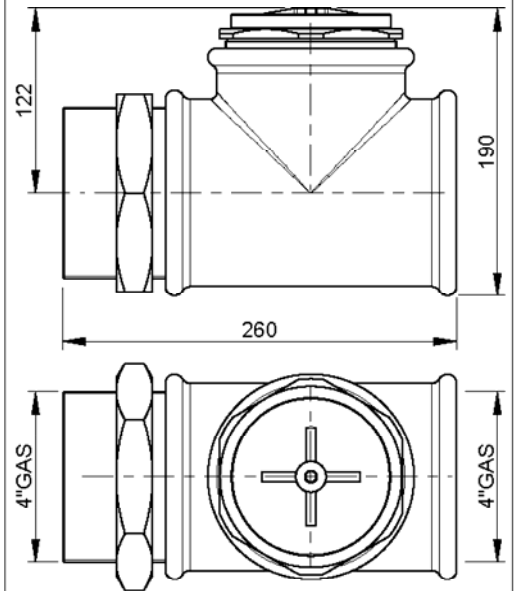

peso-weight: 10 kg

2

**VALVOLA DI SOVRAPRESSIONE  
OVERPRESSURE RELIEF VALVE**  
tipo-type: SV15T

Scala-Scale 1:5

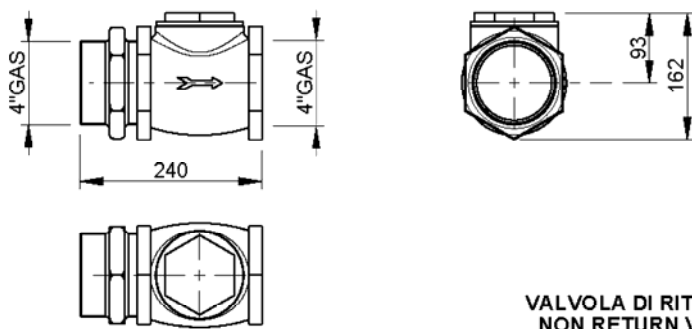

peso-weight: 7 kg

3

**VALVOLA DI RITEGNO  
NON RETURN VALVE**  
tipo-type: VR15

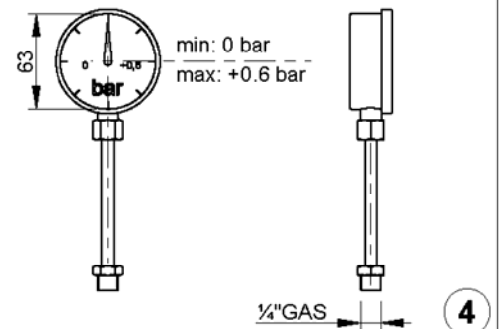

1/4"GAS

4

**MANOMETRO  
PRESSURE GAUGE**

Scala-Scale 1:5

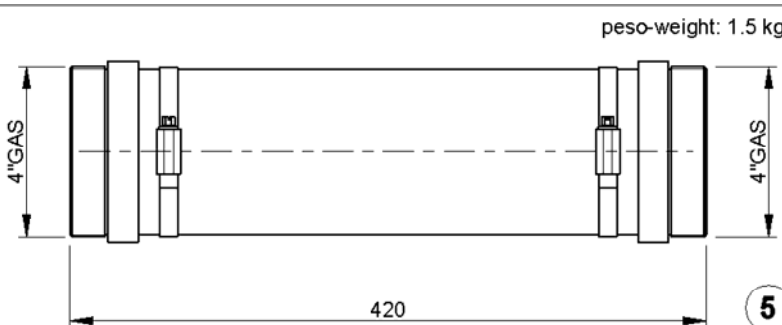

peso-weight: 1.5 kg

5

**MANICOTTO FLESSIBILE  
FLEXIBLE HOSE**  
tipo-type: FH15

Scala-Scale 1:5

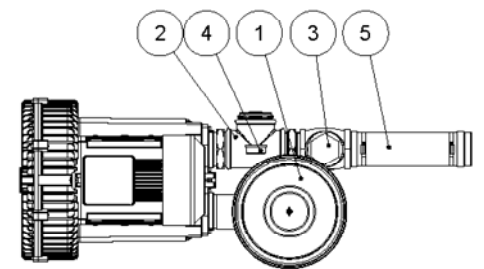

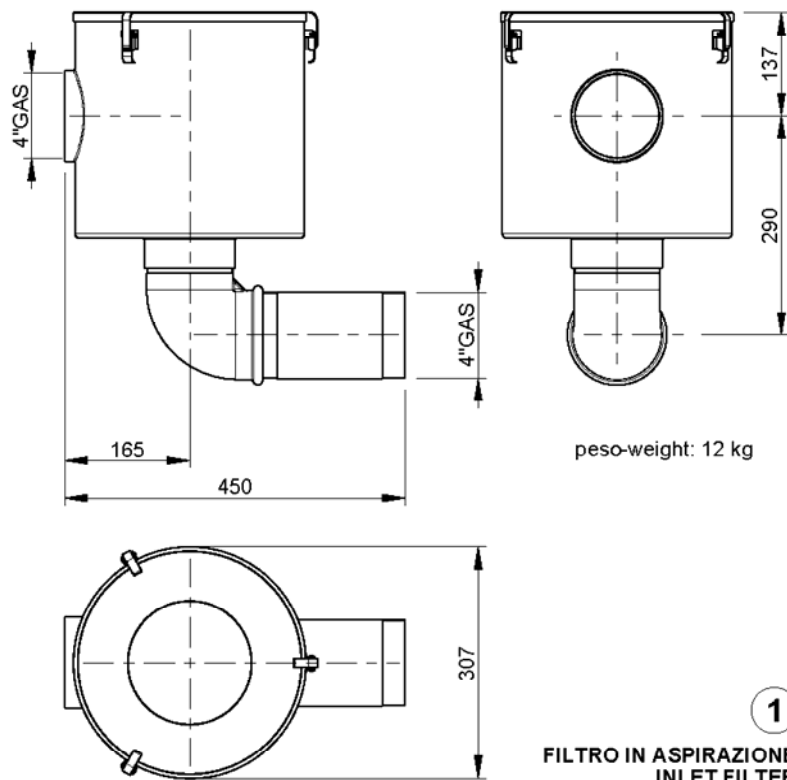

peso-weight: 12 kg

1

**FILTRO IN ASPIRAZIONE  
INLET FILTER**  
tipo-type: IF16AH

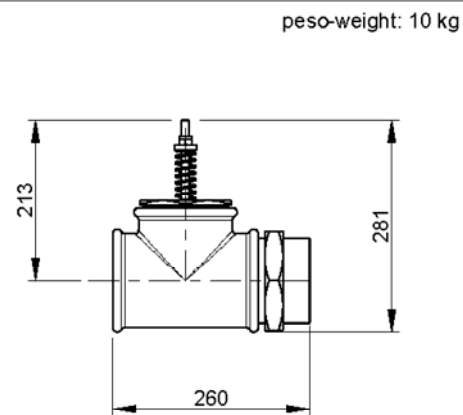

peso-weight: 10 kg

2

**VALVOLA ROMPIVUOTO  
VACUUM RELIEF VALVE**  
tipo-type: VSV15

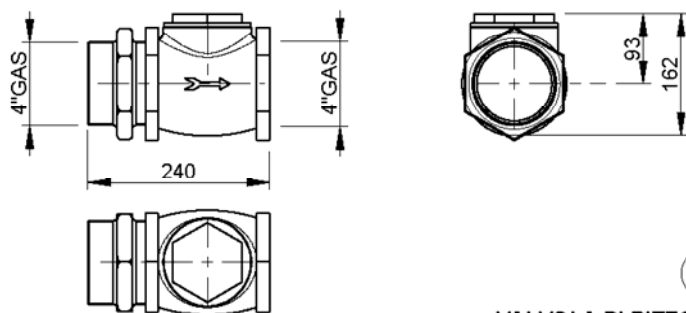

peso-weight: 7 kg

3

**VALVOLA DI RITEGNO  
NON RETURN VALVE**  
tipo-type: VR15

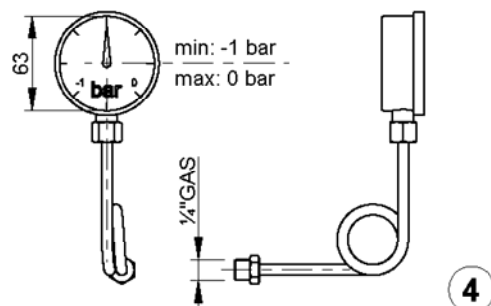

Scala-Scale 1:5

4

**VACUOMETRO  
VACUUM GAUGE**

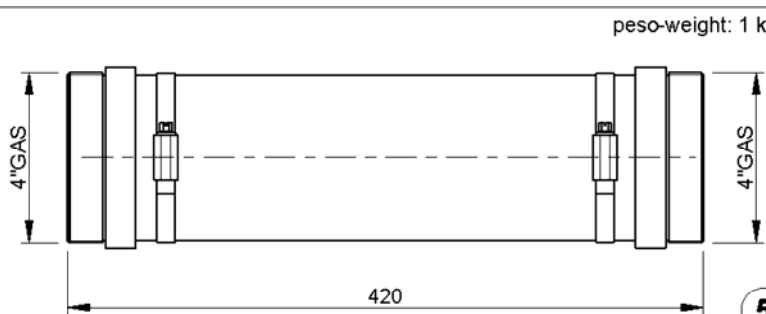

peso-weight: 1 kg

5

**MANICOTTO FLESSIBILE  
FLEXIBLE HOSE**  
tipo-type: FH15

Scala-Scale 1:5

